

00546

**BB5HD Series
Heavy-Duty Spectra®
Back Box**

Installation Manual

C2429M (3/01)

CONTENTS

- IMPORTANT SAFEGUARDS AND WARNINGS** 3
- DESCRIPTION** 4
 - MODELS 4
- UNPACKING INSTRUCTIONS** 4
- INSTALLATION IN-CEILING MODELS** 5
 - STEP 1 - PREPARE CEILING 5
 - STEP 3 - INSTALL THE BACK BOX 5
 - STEP 2 - INSTALL THE MOUNTING PLATES 5
 - STEP 5 - INSTALL DOME DRIVE 6
 - STEP 4 - WIRE CIRCUIT BOARD 6
 - STEP 6 - INSTALL LOWER DOME 6
- INSTALLATION PENDANT MODELS** 7
 - STEP 1 - MOUNT AND INSTALL THE BACK BOX 7
 - STEP 2 - WIRE CIRCUIT BOARD 7
 - STEP 3 - INSTALL DOME DRIVE 8
 - STEP 4 - INSTALL LOWER DOME 8
- TROUBLESHOOTING** 9
- APPENDIX** 10
- SPECIFICATIONS** 14
- WARRANTY AND RETURN INFORMATION** 16

LIST OF ILLUSTRATIONS

- Figure 1. Dimension Drawing 15

LIST OF TABLES

- Table A. Video Coaxial Cable Wiring Distances 10
- Table B. 24 VAC Wiring Distances 10
- Table C. Switch Settings for SW1 10
- Table D. Switch Settings for SW2 – P-Type Control 11
- Table E. Switch Settings for SW2 – D-Type Control 11

IMPORTANT SAFEGUARDS AND WARNINGS

Prior to installation and use of this product, the following WARNINGS should be observed.

1. Installation and servicing should only be done by qualified service personnel and conform to all local codes.
2. Unless the unit is specifically marked as a NEMA Type 3, 3R, 3S, 4, 4X, 6, or 6P enclosure, it is designed for indoor use only and it must not be installed where exposed to rain and moisture.
3. Only use replacement parts recommended by Pelco.
4. After replacement/repair of this unit's electrical components, conduct a resistance measurement between line and exposed parts to verify the exposed parts have not been connected to line circuitry.
5. The installation method and materials should be capable of supporting four times the weight of the enclosure, pan/tilt, camera and lens combination.

The product and/or manual may bear the following marks:



This symbol indicates that dangerous voltage constituting a risk of electric shock is present within this unit.



This symbol indicates that there are important operating and maintenance instructions in the literature accompanying this unit.



Please thoroughly familiarize yourself with the information in this manual prior to installation and operation.

DESCRIPTION

The Heavy-duty Spectra is perfect for installations where structural integrity and vandalism are a priority. The system features barrel key locks, heavy-duty construction and a thick acrylic lower dome. The in-ceiling model has a reinforced bracket mounting system for installation in a fixed ceiling. Pendant models can be mounted to a pole or wall using the IWM Spectra wall mount.

MODELS

BB5HD-F	In-ceiling back box with reinforced bracket-mounting system
BB5HD-PG	Indoor, pendant style back box with reinforced sun shroud
BB5HD-PG-E	Environmental, pendant style back box with heater, fan and reinforced sun shroud

Lower dome models are not interchangeable. Each heavy-duty lower dome is designed for a specific back box model. Install the correct lower dome to the right back box. See the following chart.

Back Box Model	Lower Dome Model	Lower Dome with Cage Model
BB5HD-F	LD5HDF-1	LD5HDCF-1
BB5HD-PG	LD5HDPG-1	LD5HDCPG-1
BB5HD-PG-E	LD5HDPG-E1	LD5HDCPG-E1

Spectra Lite and all Spectra II model dome drives are compatible with all Heavy-Duty back box models.

UNPACKING INSTRUCTIONS

If an item needs to be returned to the factory, consult the WARRANTY AND RETURN section of this manual for instructions.

The following items are supplied:

IN-CEILING MODELS

- 1 Back box
- 1 Mounting plate
- 2 Back mounting plates
- 1 Parts bag
 - 2 8-32 x .275-inch screws
 - 1 Conduit fitting
 - 1 Safety chain bracket
 - 1 Lock nut
 - 1 Compass tool

PENDANT MODELS

- 1 Back box
- 1 Tube of thread compound

INSTALLATION IN-CEILING MODEL

STEP 1 - PREPARE CEILING



a. Locate the center point of the mounting location. Drill a hole in the ceiling using a 3/32-inch drill.

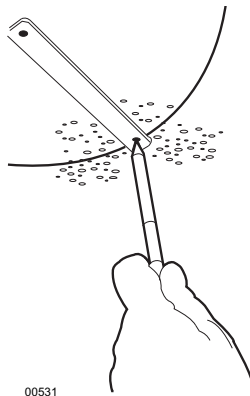

b. Insert the compass tool into the hole. Draw a circle on the ceiling using the compass tool and a pencil. Cut the circle out of the ceiling.

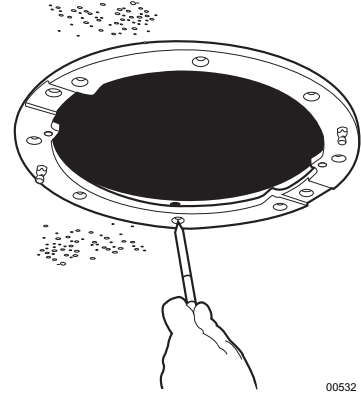

c. Use the mounting ring as a template and mark the hole pattern onto the mounting surface. Prepare the holes.

STEP 2 - INSTALL THE MOUNTING PLATES

Use the eight 10-32 x 3-inch screws (supplied) and install the mounting ring and two back mounting plates.

a. Line up the mount ring with the eight fastener holes.
b. Feed one back mounting plate through the hole in the ceiling and line up with four fastener holes.

c. Install fasteners through the mount ring, ceiling and out the back mounting plate.
d. Install second back mounting plate.

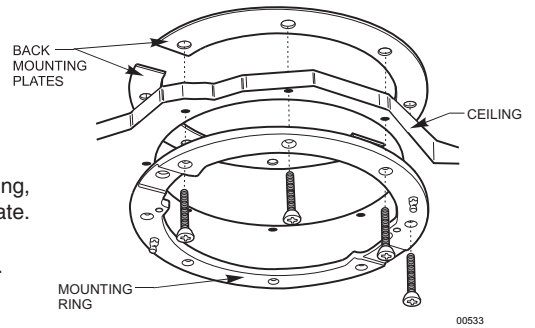

STEP 3 - INSTALL THE BACK BOX

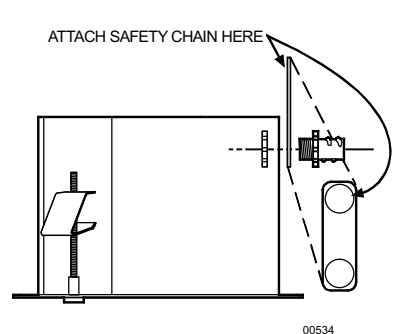

a. Attach the conduit fitting, lock nut, and safety chain bracket. Install a safety chain/cable (not supplied) that will support up to 16 pounds (7.3 kg).

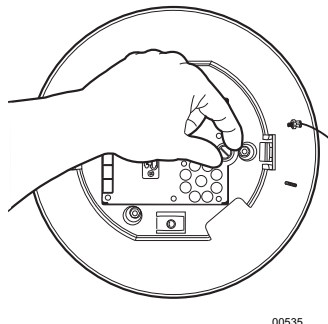

b. Turn the thumbscrew and open the hinged door to the back box. Pull wiring into the back box through the conduit fitting. Refer to Tables A and B in the Appendix for wiring distances.

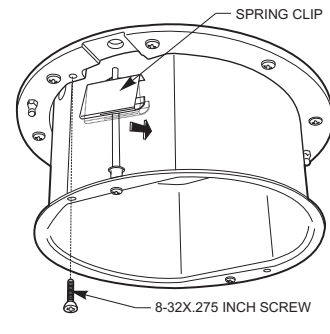

c. Compress the spring clips on the back box and push it through the hole, until the clips spring back. Tighten the screws until you hear a clicking noise. Insert the two 8-32 x .275-inch screws to secure the back box to the mount ring.

STEP 4 - WIRE CIRCUIT BOARD

Attach the wiring to the circuit board inside the back box. When finished, close the door to the back box and turn on the power. The red LED will light.

IMPORTANT: If the LED does not light, refer to the *Troubleshooting* section.

NOTE: Aux 1 - Maximum 2A at low voltage (<40V)
Aux 2 - Maximum 150 vA at 32 VDC

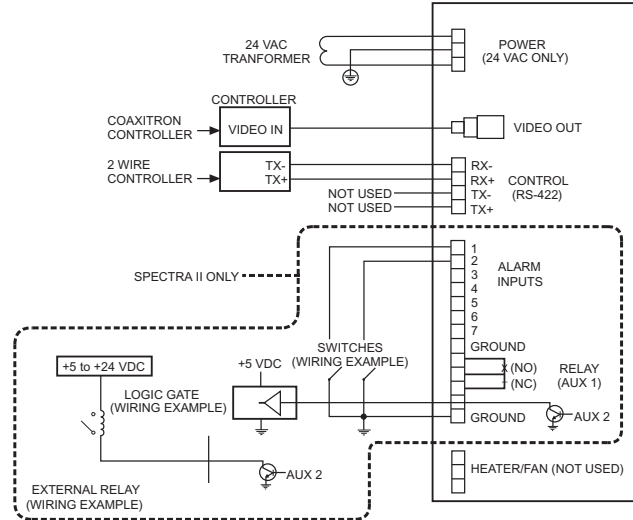

00542

STEP 5 - INSTALL DOME DRIVE

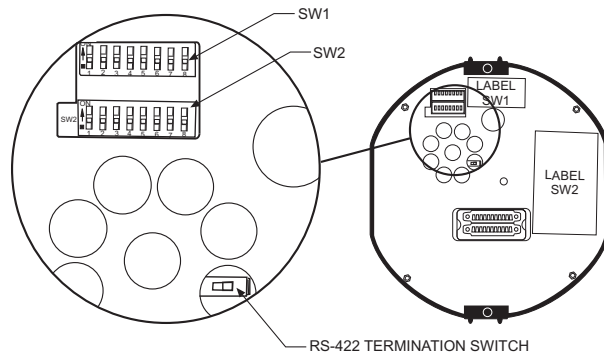

00538

a. Set the DIP switches for SW1 and SW2 on the bottom of the dome drive for the appropriate receiver address. Refer to the labels on the dome drive or Tables C through E in the Appendix in the back of this manual.

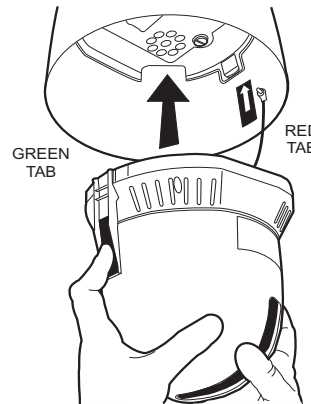

00539

b. Line up the green and red tabs with the green and red labels. Push in on the tabs. Insert the side with the green tab, then the side with red tab. Continue pushing on the ends of the tabs until both sides click into place.

STEP 6 - INSTALL LOWER DOME

- Attach the lower dome trim leash to one of the 8-32 x .275-inch screws that secure the back box to the mounting ring.
- Insert both keys in the barrel locks. Turn keys clockwise to the unlocked position. Keys can not be removed from lock in the unlocked position.
- Align pegs (located on the mount ring) with the peg receptacles (located on the inside of the lower dome).
- Place lower dome over back box. Hold and turn both keys to the locked position.

TO USE YOUR DOME, REFER TO THE OPERATION AND PROGRAMMING MANUAL.

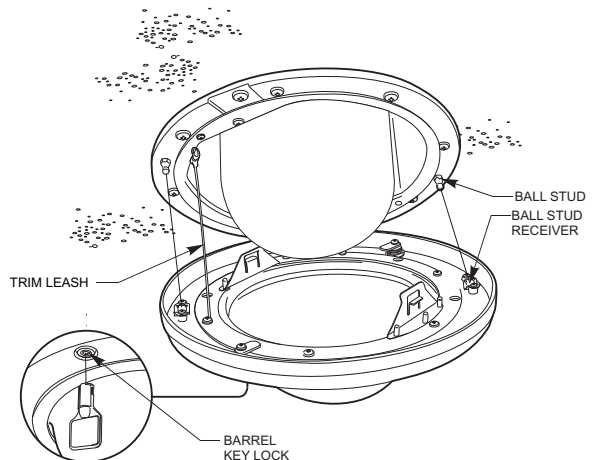

00497

INSTALLATION PENDANT MODELS

STEP 1 - MOUNT AND INSTALL THE BACK BOX

NOTE: If installing outdoors make sure the installation is properly sealed to keep moisture out.

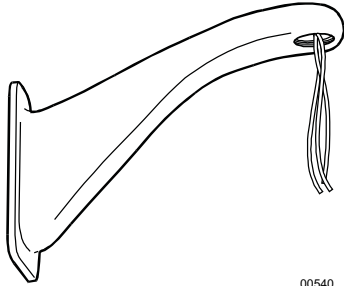

00540

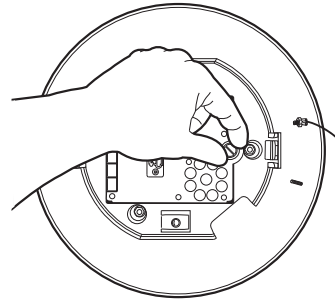

00535

a. Install the mount for the pendant dome. Refer to the instructions supplied with the mount. Bring the wiring for the dome through the mount. Refer to Tables A and B in the Appendix for wiring distances.

b. Turn the thumbscrew and open the hinged door located inside the back box.

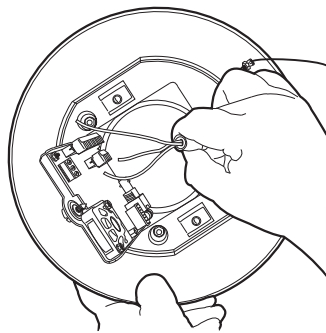

c. Pull wiring from the mount into the back box.

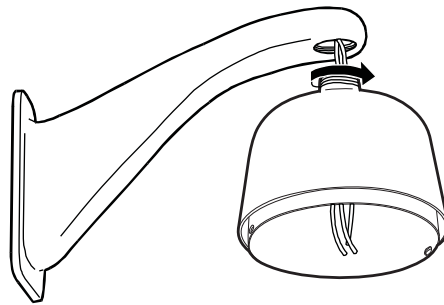

00541

d. Screw the back box into the mount. If outdoors, apply thread compound (provided) to the threads on the back box.

STEP 2 - WIRE CIRCUIT BOARD

Attach the wiring to the interconnect circuit board inside the back box. Close the door to the back box. Turn on power to the back box. The red LED will light.

IMPORTANT: If the LED does not light, refer to the *Troubleshooting section*.

NOTE: Aux 1 - Maximum 2A at low voltage (<40V)
Aux 2 - Maximum 150 vA at 32 VDC

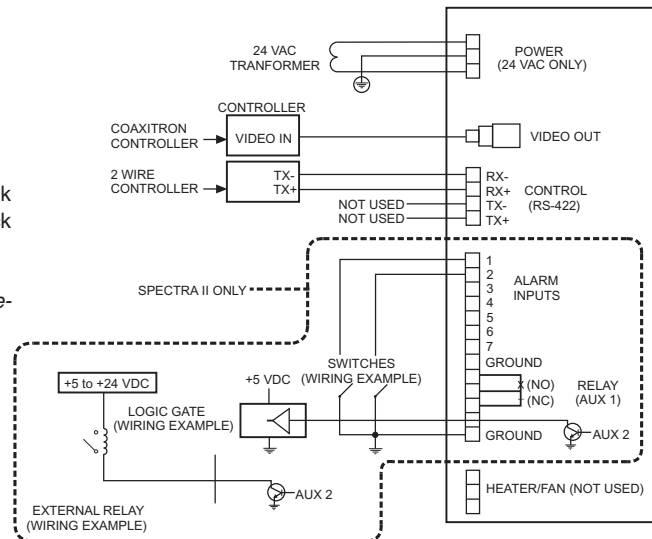

00542

STEP 3 - INSTALL DOME DRIVE

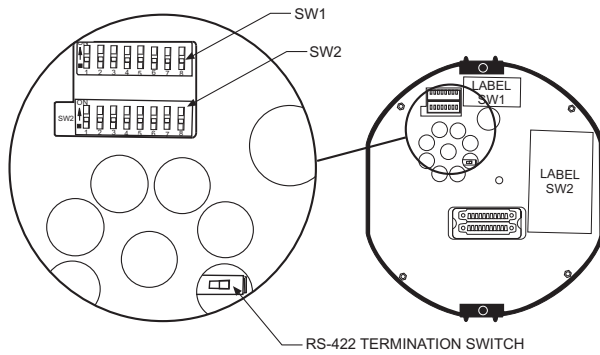

00538

- a. Set the DIP switches for SW1 and SW2 on the bottom of the dome drive for the appropriate receiver address. Refer to the labels on the dome drive or tables C through E in the Appendix in the back of this manual.

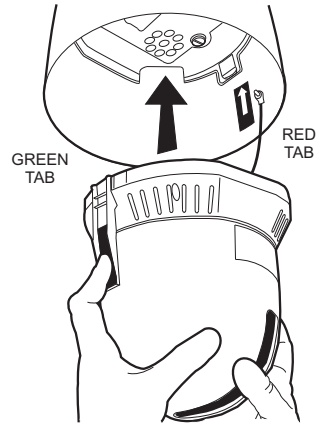

00539

- b. Line up the green and red tabs with the green and red labels. Push in on the tabs. Insert the side with the green tab, then the side with red tab. Continue pushing on the ends of the tabs until both sides click into place.

STEP 4 - INSTALL LOWER DOME

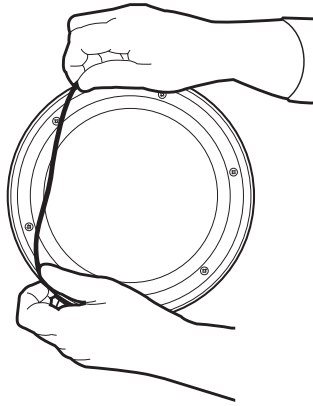

00543

- a. Lightly apply O-ring lubricant to the O-ring. Install the O-ring in the groove on the trim ring of the lower dome.

Attach the back box trim leash to a retainer screw inside the lower dome.

Environmental Model only: Plug the two-pin heater connection in the lower dome into the mating connector in the back box.

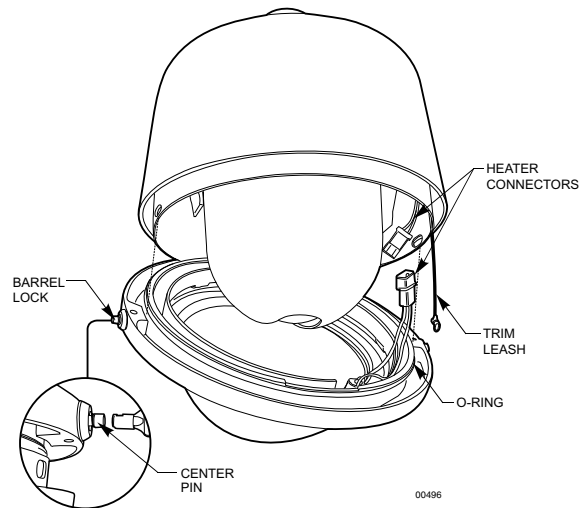

00496

- b. Align barrel locks in lower dome with the holes located on each side of the back box. Push lower dome onto back box. Press the pins of the barrel locks IN to secure the lower dome.

TO USE YOUR DOME, REFER TO THE OPERATION AND PROGRAMMING MANUAL.

TROUBLESHOOTING

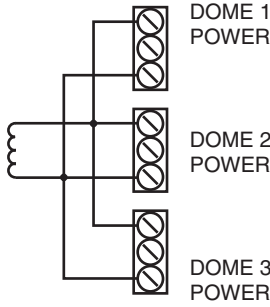
PROBLEM	POSSIBLE CAUSE	SOLUTION
<p>Unit does not operate. The controller is not communicating with the Spectra unit.</p>	<p>Check to see if the red LED on the circuit board in the back box is lit.</p> <ol style="list-style-type: none"> 1. The red LED is not lit. <ol style="list-style-type: none"> a. Fuse is bad. b. 24 VAC power source is not connected or back box is bad. 2. The red LED is lit. <ol style="list-style-type: none"> a. Wiring is incorrect or is not fully seated. b. DIP switch settings are incorrect. 	<ol style="list-style-type: none"> a. Check fuse on the circuit board. Replace fuse if it is bad. To order a fuse from Pelco, specify the part number FUS1.6-5X20FAST. This is a 1.6-ampere fuse, 5 x 20 mm, fast blow. b. Use a voltmeter to check if 24 VAC is getting to the power connector on the circuit board. If NO, check your power supply. If YES, return the back box to the factory for repair. <ol style="list-style-type: none"> a. Check all connections to the circuit board. Make sure that all connections are fully seated and the board is wired correctly. b. Check the DIP switch settings on the dome drive (refer to Tables C, D, and E). If the unit still does not operate, turn off power and replace the dome drive with a good unit, if you have a spare. Check the switch settings on the substitute dome drive before installing it. (If you do not have a spare, return the dome drive and back box to the factory.) If you substituted a dome drive and the unit operates, the original dome drive is bad (return the dome drive to the factory). If the unit still does not operate, then the circuit board is bad (return the back box to the factory).
<p>Fan does not operate.</p>	<p>Fan connections are not fully seated.</p>	<p>Make sure the connector for the fan is fully seated. If the fan still does not operate, return the back box and dome drive to the factory for repair.</p>
<p>Vertical roll on monitor when switching between cameras.</p>	<p>Cameras are out of phase.</p>	<p>If you are wiring more than one dome to the same transformer, it is important to wire the power connector in each dome the same way. That is, the wiring from one side of the transformer must be connected to the same connector on each dome.</p> <p>WARNING: Make sure you wire power to the outer connectors of the terminal block and ground to the middle connector. Otherwise, you could damage the dome.</p> 

00095

APPENDIX

Table A. Video Coaxial Cable Wiring Distances

Cable Type*	Maximum Distance
RG59/U	750 ft (229 m)
RG6/U	1,000 ft (305 m)
RG11/U	1,500 ft (457 m)

* Minimum cable requirements:
75 ohms impedance. All-copper center conductor.
95% braided copper shield.

Table B. 24 VAC Wiring Distances

The following are the recommended maximum distances for 24 VAC with a 10-percent voltage drop. (Ten percent is generally the maximum allowable voltage drop for AC-powered devices.)

Wire Gauge

	20	18	16	14	12	10
30 vA	94 ft (28 m)	150 ft (45 m)	238 ft (115 m)	380 ft (72 m)	603 ft (183 m)	960 ft (292 m)
75 vA	37 ft (11 m)	60 ft (18 m)	95 ft (29 m)	152 ft (46 m)	241 ft (73 m)	384 ft (117 m)

NOTE: Input power for the dome is 24 VAC only. Power consumption is 30 vA per dome for indoor models and 75 vA for outdoor models.

Use a 24 VAC transformer with the following minimum vA:
40 vA per dome For indoor models (without heater)
100 vA per dome For outdoor models (with heater)

Table C. Switch Settings for SW1

Control Type	Switch Setting							
	SW1-1	SW1-2	SW1-3	SW1-4	SW1-5	SW1-6	SW1-7	SW1-8
Coaxitron®	OFF	OFF	OFF	OFF	OFF	OFF	OFF	OFF**
P-Type Control	ON	OFF	OFF	OFF	OFF	OFF	OFF	OFF**
D-Type Control	OFF	ON	OFF	OFF	OFF	OFF	OFF*	OFF**

NOTES: Switches SW 1-3 through SW 1-6 MUST be OFF.

D-type control is RS-422 that is compatible with Pelco's CM6700, MPT9500, CM8500, and Genex® controllers or with American Dynamics control systems using the AD2083 Translator.

P-type control is RS-422 that is compatible with Pelco's CM6700/CM9750/CM9760 and Genex control systems.

- * OFF- Use with controllers that have more than 32 presets.
- ON- Use with American Dynamics controllers (32 presets).
- ** OFF - Use with all control systems except CM9502 with **variable** speed keyboards.
- For CM9502 with **fixed** speed keyboards, set switch OFF.
- ON - Use with CM9502 with **variable** speed keyboards for smoother joystick control.

Table D. Switch Settings for SW2 – P-Type Control

NOTE: For Coaxitron controls, SW2 is not used; set all switches OFF. For D-type control systems, refer to Table E.

Receiver Address	Switch Setting					Receiver Address	Switch Setting				
	SW2-1	SW2-2	SW2-3	SW2-4	SW2-5		SW2-1	SW2-2	SW2-3	SW2-4	SW2-5
1	OFF	OFF	OFF	OFF	OFF	17	OFF	OFF	OFF	OFF	ON
2	ON	OFF	OFF	OFF	OFF	18	ON	OFF	OFF	OFF	ON
3	OFF	ON	OFF	OFF	OFF	19	OFF	ON	OFF	OFF	ON
4	ON	ON	OFF	OFF	OFF	20	ON	ON	OFF	OFF	ON
5	OFF	OFF	ON	OFF	OFF	21	OFF	OFF	ON	OFF	ON
6	ON	OFF	ON	OFF	OFF	22	ON	OFF	ON	OFF	ON
7	OFF	ON	ON	OFF	OFF	23	OFF	ON	ON	OFF	ON
8	ON	ON	ON	OFF	OFF	24	ON	ON	ON	OFF	ON
9	OFF	OFF	OFF	ON	OFF	25	OFF	OFF	OFF	ON	ON
10	ON	OFF	OFF	ON	OFF	26	ON	OFF	OFF	ON	ON
11	OFF	ON	OFF	ON	OFF	27	OFF	ON	OFF	ON	ON
12	ON	ON	OFF	ON	OFF	28	ON	ON	OFF	ON	ON
13	OFF	OFF	ON	ON	OFF	29	OFF	OFF	ON	ON	ON
14	ON	OFF	ON	ON	OFF	30	ON	OFF	ON	ON	ON
15	OFF	ON	ON	ON	OFF	31	OFF	ON	ON	ON	ON
16	ON	ON	ON	ON	OFF	32	ON	ON	ON	ON	ON

Baud Rate	Switch Setting		
	SW2-6	SW2-7	SW2-8
2400	OFF	OFF	OFF
4800	ON	OFF	OFF
9600	OFF	ON	OFF

Table E. Switch Settings for SW2 – D-Type Control

NOTE: For Coaxitron controls, SW2 is not used; set all switches OFF. For P-type control systems, refer to Table D.

Receiver Address	Switch Setting								Receiver Address	Switch Setting							
	SW2-1	SW2-2	SW2-3	SW2-4	SW2-5	SW2-6	SW2-7	SW2-8		SW2-1	SW2-2	SW2-3	SW2-4	SW2-5	SW2-6	SW2-7	SW2-8
1	ON	OFF	OFF	OFF	OFF	OFF	OFF	OFF	25	ON	OFF	OFF	ON	ON	OFF	OFF	OFF
2	OFF	ON	OFF	OFF	OFF	OFF	OFF	OFF	26	OFF	ON	OFF	ON	ON	OFF	OFF	OFF
3	ON	ON	OFF	OFF	OFF	OFF	OFF	OFF	27	ON	ON	OFF	ON	ON	OFF	OFF	OFF
4	OFF	OFF	ON	OFF	OFF	OFF	OFF	OFF	28	OFF	OFF	ON	ON	ON	OFF	OFF	OFF
5	ON	OFF	ON	OFF	OFF	OFF	OFF	OFF	29	ON	OFF	ON	ON	ON	OFF	OFF	OFF
6	OFF	ON	ON	OFF	OFF	OFF	OFF	OFF	30	OFF	ON	ON	ON	ON	OFF	OFF	OFF
7	ON	ON	ON	OFF	OFF	OFF	OFF	OFF	31	ON	ON	ON	ON	ON	OFF	OFF	OFF
8	OFF	OFF	OFF	ON	OFF	OFF	OFF	OFF	32	OFF	OFF	OFF	OFF	OFF	ON	OFF	OFF
9	ON	OFF	OFF	ON	OFF	OFF	OFF	OFF	33	ON	OFF	OFF	OFF	OFF	ON	OFF	OFF
10	OFF	ON	OFF	ON	OFF	OFF	OFF	OFF	34	OFF	ON	OFF	OFF	OFF	ON	OFF	OFF
11	ON	ON	OFF	ON	OFF	OFF	OFF	OFF	35	ON	ON	OFF	OFF	OFF	ON	OFF	OFF
12	OFF	OFF	ON	ON	OFF	OFF	OFF	OFF	36	OFF	OFF	ON	OFF	OFF	ON	OFF	OFF
13	ON	OFF	ON	ON	OFF	OFF	OFF	OFF	37	ON	OFF	ON	OFF	OFF	ON	OFF	OFF
14	OFF	ON	ON	ON	OFF	OFF	OFF	OFF	38	OFF	ON	ON	OFF	OFF	ON	OFF	OFF
15	ON	ON	ON	ON	OFF	OFF	OFF	OFF	39	ON	ON	ON	OFF	OFF	ON	OFF	OFF
16	OFF	OFF	OFF	OFF	ON	OFF	OFF	OFF	40	OFF	OFF	OFF	ON	OFF	ON	OFF	OFF
17	ON	OFF	OFF	OFF	ON	OFF	OFF	OFF	41	ON	OFF	OFF	ON	OFF	ON	OFF	OFF
18	OFF	ON	OFF	OFF	ON	OFF	OFF	OFF	42	OFF	ON	OFF	ON	OFF	ON	OFF	OFF
19	ON	ON	OFF	OFF	ON	OFF	OFF	OFF	43	ON	ON	OFF	ON	OFF	ON	OFF	OFF
20	OFF	OFF	ON	OFF	ON	OFF	OFF	OFF	44	OFF	OFF	ON	ON	OFF	ON	OFF	OFF
21	ON	OFF	ON	OFF	ON	OFF	OFF	OFF	45	ON	OFF	ON	ON	OFF	ON	OFF	OFF
22	OFF	ON	ON	OFF	ON	OFF	OFF	OFF	46	OFF	ON	ON	ON	OFF	ON	OFF	OFF
23	ON	ON	ON	OFF	ON	OFF	OFF	OFF	47	ON	ON	ON	ON	OFF	ON	OFF	OFF
24	OFF	OFF	OFF	ON	ON	OFF	OFF	OFF	48	OFF	OFF	OFF	OFF	ON	ON	OFF	OFF

(Continued on next page)

Table E. Switch Settings for SW2 – D-Type Control (continued)

Receiver Address	Switch Setting							
	SW2-1	SW2-2	SW2-3	SW2-4	SW2-5	SW2-6	SW2-7	SW2-8
49	ON	OFF	OFF	OFF	ON	ON	OFF	OFF
50	OFF	ON	OFF	OFF	ON	ON	OFF	OFF
51	ON	ON	OFF	OFF	ON	ON	OFF	OFF
52	OFF	OFF	ON	OFF	ON	ON	OFF	OFF
53	ON	OFF	ON	OFF	ON	ON	OFF	OFF
54	OFF	ON	ON	OFF	ON	ON	OFF	OFF
55	ON	ON	ON	OFF	ON	ON	OFF	OFF
56	OFF	OFF	OFF	ON	ON	ON	OFF	OFF
57	ON	OFF	OFF	ON	ON	ON	OFF	OFF
58	OFF	ON	OFF	ON	ON	ON	OFF	OFF
59	ON	ON	OFF	ON	ON	ON	OFF	OFF
60	OFF	OFF	ON	ON	ON	ON	OFF	OFF
61	ON	OFF	ON	ON	ON	ON	OFF	OFF
62	OFF	ON	ON	ON	ON	ON	OFF	OFF
63	ON	ON	ON	ON	ON	ON	OFF	OFF
64	OFF	OFF	OFF	OFF	OFF	OFF	ON	OFF
65	ON	OFF	OFF	OFF	OFF	OFF	ON	OFF
66	OFF	ON	OFF	OFF	OFF	OFF	ON	OFF
67	ON	ON	OFF	OFF	OFF	OFF	ON	OFF
68	OFF	OFF	ON	OFF	OFF	OFF	ON	OFF
69	ON	OFF	ON	OFF	OFF	OFF	ON	OFF
70	OFF	ON	ON	OFF	OFF	OFF	ON	OFF
71	ON	ON	ON	OFF	OFF	OFF	ON	OFF
72	OFF	OFF	OFF	ON	OFF	OFF	ON	OFF
73	ON	OFF	OFF	ON	OFF	OFF	ON	OFF
74	OFF	ON	OFF	ON	OFF	OFF	ON	OFF
75	ON	ON	OFF	ON	OFF	OFF	ON	OFF
76	OFF	OFF	ON	ON	OFF	OFF	ON	OFF
77	ON	OFF	ON	ON	OFF	OFF	ON	OFF
78	OFF	ON	ON	ON	OFF	OFF	ON	OFF
79	ON	ON	ON	ON	OFF	OFF	ON	OFF
80	OFF	OFF	OFF	OFF	ON	OFF	ON	OFF
81	ON	OFF	OFF	OFF	ON	OFF	ON	OFF
82	OFF	ON	OFF	OFF	ON	OFF	ON	OFF
83	ON	ON	OFF	OFF	ON	OFF	ON	OFF
84	OFF	OFF	ON	OFF	ON	OFF	ON	OFF
85	ON	OFF	ON	OFF	ON	OFF	ON	OFF
86	OFF	ON	ON	OFF	ON	OFF	ON	OFF
87	ON	ON	ON	OFF	ON	OFF	ON	OFF
88	OFF	OFF	OFF	ON	ON	OFF	ON	OFF
89	ON	OFF	OFF	ON	ON	OFF	ON	OFF
90	OFF	ON	OFF	ON	ON	OFF	ON	OFF
91	ON	ON	OFF	ON	ON	OFF	ON	OFF
92	OFF	OFF	ON	ON	ON	OFF	ON	OFF
93	ON	OFF	ON	ON	ON	OFF	ON	OFF
94	OFF	ON	ON	ON	ON	OFF	ON	OFF
95	ON	ON	ON	ON	ON	OFF	ON	OFF
96	OFF	OFF	OFF	OFF	OFF	ON	ON	OFF
97	ON	OFF	OFF	OFF	OFF	ON	ON	OFF
98	OFF	ON	OFF	OFF	OFF	ON	ON	OFF
99	ON	ON	OFF	OFF	OFF	ON	ON	OFF
100	OFF	OFF	ON	OFF	OFF	ON	ON	OFF
101	ON	OFF	ON	OFF	OFF	ON	ON	OFF
102	OFF	ON	ON	OFF	OFF	ON	ON	OFF
103	ON	ON	ON	OFF	OFF	ON	ON	OFF
104	OFF	OFF	OFF	ON	OFF	ON	ON	OFF

Receiver Address	Switch Setting							
	SW2-1	SW2-2	SW2-3	SW2-4	SW2-5	SW2-6	SW2-7	SW2-8
105	ON	OFF	OFF	ON	OFF	ON	ON	OFF
106	OFF	ON	OFF	ON	OFF	ON	ON	OFF
107	ON	ON	OFF	ON	OFF	ON	ON	OFF
108	OFF	OFF	ON	ON	OFF	ON	ON	OFF
109	ON	OFF	ON	ON	OFF	ON	ON	OFF
110	OFF	ON	ON	ON	OFF	ON	ON	OFF
111	ON	ON	ON	ON	OFF	ON	ON	OFF
112	OFF	OFF	OFF	OFF	ON	ON	ON	OFF
113	ON	OFF	OFF	OFF	ON	ON	ON	OFF
114	OFF	ON	OFF	OFF	ON	ON	ON	OFF
115	ON	ON	OFF	OFF	ON	ON	ON	OFF
116	OFF	OFF	ON	OFF	ON	ON	ON	OFF
117	ON	OFF	ON	OFF	ON	ON	ON	OFF
118	OFF	ON	ON	OFF	ON	ON	ON	OFF
119	ON	ON	ON	OFF	ON	ON	ON	OFF
120	OFF	OFF	OFF	ON	ON	ON	ON	OFF
121	ON	OFF	OFF	ON	ON	ON	ON	OFF
122	OFF	ON	OFF	ON	ON	ON	ON	OFF
123	ON	ON	OFF	ON	ON	ON	ON	OFF
124	OFF	OFF	ON	ON	ON	ON	ON	OFF
125	ON	OFF	ON	ON	ON	ON	ON	OFF
126	OFF	ON	ON	ON	ON	ON	ON	OFF
127	ON	ON	ON	ON	ON	ON	ON	OFF
128	OFF	OFF	OFF	OFF	OFF	OFF	OFF	ON
129	ON	OFF	OFF	OFF	OFF	OFF	OFF	ON
130	OFF	ON	OFF	OFF	OFF	OFF	OFF	ON
131	ON	ON	OFF	OFF	OFF	OFF	OFF	ON
132	OFF	OFF	ON	OFF	OFF	OFF	OFF	ON
133	ON	OFF	ON	OFF	OFF	OFF	OFF	ON
134	OFF	ON	ON	OFF	OFF	OFF	OFF	ON
135	ON	ON	ON	OFF	OFF	OFF	OFF	ON
136	OFF	OFF	OFF	ON	OFF	OFF	OFF	ON
137	ON	OFF	OFF	ON	OFF	OFF	OFF	ON
138	OFF	ON	OFF	ON	OFF	OFF	OFF	ON
139	ON	ON	OFF	ON	OFF	OFF	OFF	ON
140	OFF	OFF	ON	ON	OFF	OFF	OFF	ON
141	ON	OFF	ON	ON	OFF	OFF	OFF	ON
142	OFF	ON	ON	ON	OFF	OFF	OFF	ON
143	ON	ON	ON	ON	OFF	OFF	OFF	ON
144	OFF	OFF	OFF	OFF	ON	OFF	OFF	ON
145	ON	OFF	OFF	OFF	ON	OFF	OFF	ON
146	OFF	ON	OFF	OFF	ON	OFF	OFF	ON
147	ON	ON	OFF	OFF	ON	OFF	OFF	ON
148	OFF	OFF	ON	OFF	ON	OFF	OFF	ON
149	ON	OFF	ON	OFF	ON	OFF	OFF	ON
150	OFF	ON	ON	OFF	ON	OFF	OFF	ON
151	ON	ON	ON	OFF	ON	OFF	OFF	ON
152	OFF	OFF	OFF	ON	ON	OFF	OFF	ON
153	ON	OFF	OFF	ON	ON	OFF	OFF	ON
154	OFF	ON	OFF	ON	ON	OFF	OFF	ON
155	ON	ON	OFF	ON	ON	OFF	OFF	ON
156	OFF	OFF	ON	ON	ON	OFF	OFF	ON
157	ON	OFF	ON	ON	ON	OFF	OFF	ON
158	OFF	ON	ON	ON	ON	OFF	OFF	ON
159	ON	ON	ON	ON	ON	OFF	OFF	ON
160	OFF	OFF	OFF	OFF	OFF	ON	OFF	ON

(Continued on next page)

Table E. Switch Settings for SW2 – D-Type Control (continued)

Receiver Address	Switch Setting							
	SW2-1	SW2-2	SW2-3	SW2-4	SW2-5	SW2-6	SW2-7	SW2-8
161	ON	OFF	OFF	OFF	OFF	ON	OFF	ON
162	OFF	ON	OFF	OFF	OFF	ON	OFF	ON
163	ON	ON	OFF	OFF	OFF	ON	OFF	ON
164	OFF	OFF	ON	OFF	OFF	ON	OFF	ON
165	ON	OFF	ON	OFF	OFF	ON	OFF	ON
166	OFF	ON	ON	OFF	OFF	ON	OFF	ON
167	ON	ON	ON	OFF	OFF	ON	OFF	ON
168	OFF	OFF	OFF	ON	OFF	ON	OFF	ON
169	ON	OFF	OFF	ON	OFF	ON	OFF	ON
170	OFF	ON	OFF	ON	OFF	ON	OFF	ON
171	ON	ON	OFF	ON	OFF	ON	OFF	ON
172	OFF	OFF	ON	ON	OFF	ON	OFF	ON
173	ON	OFF	ON	ON	OFF	ON	OFF	ON
174	OFF	ON	ON	ON	OFF	ON	OFF	ON
175	ON	ON	ON	ON	OFF	ON	OFF	ON
176	OFF	OFF	OFF	OFF	ON	ON	OFF	ON
177	ON	OFF	OFF	OFF	ON	ON	OFF	ON
178	OFF	ON	OFF	OFF	ON	ON	OFF	ON
179	ON	ON	OFF	OFF	ON	ON	OFF	ON
180	OFF	OFF	ON	OFF	ON	ON	OFF	ON
181	ON	OFF	ON	OFF	ON	ON	OFF	ON
182	OFF	ON	ON	OFF	ON	ON	OFF	ON
183	ON	ON	ON	OFF	ON	ON	OFF	ON
184	OFF	OFF	OFF	ON	ON	ON	OFF	ON
185	ON	OFF	OFF	ON	ON	ON	OFF	ON
186	OFF	ON	OFF	ON	ON	ON	OFF	ON
187	ON	ON	OFF	ON	ON	ON	OFF	ON
188	OFF	OFF	ON	ON	ON	ON	OFF	ON
189	ON	OFF	ON	ON	ON	ON	OFF	ON
190	OFF	ON	ON	ON	ON	ON	OFF	ON
191	ON	ON	ON	ON	ON	ON	OFF	ON
192	OFF	OFF	OFF	OFF	OFF	OFF	ON	ON
193	ON	OFF	OFF	OFF	OFF	OFF	ON	ON
194	OFF	ON	OFF	OFF	OFF	OFF	ON	ON
195	ON	ON	OFF	OFF	OFF	OFF	ON	ON
196	OFF	OFF	ON	OFF	OFF	OFF	ON	ON
197	ON	OFF	ON	OFF	OFF	OFF	ON	ON
198	OFF	ON	ON	OFF	OFF	OFF	ON	ON
199	ON	ON	ON	OFF	OFF	OFF	ON	ON
200	OFF	OFF	OFF	ON	OFF	OFF	ON	ON
201	ON	OFF	OFF	ON	OFF	OFF	ON	ON
202	OFF	ON	OFF	ON	OFF	OFF	ON	ON
203	ON	ON	OFF	ON	OFF	OFF	ON	ON
204	OFF	OFF	ON	ON	OFF	OFF	ON	ON
205	ON	OFF	ON	ON	OFF	OFF	ON	ON
206	OFF	ON	ON	ON	OFF	OFF	ON	ON
207	ON	ON	ON	ON	OFF	OFF	ON	ON
208	OFF	OFF	OFF	OFF	ON	OFF	ON	ON

Receiver Address	Switch Setting							
	SW2-1	SW2-2	SW2-3	SW2-4	SW2-5	SW2-6	SW2-7	SW2-8
209	ON	OFF	OFF	OFF	ON	OFF	ON	ON
210	OFF	ON	OFF	OFF	ON	OFF	ON	ON
211	ON	ON	OFF	OFF	ON	OFF	ON	ON
212	OFF	OFF	ON	OFF	ON	OFF	ON	ON
213	ON	OFF	ON	OFF	ON	OFF	ON	ON
214	OFF	ON	ON	OFF	ON	OFF	ON	ON
215	ON	ON	ON	OFF	ON	OFF	ON	ON
216	OFF	OFF	OFF	ON	ON	OFF	ON	ON
217	ON	OFF	OFF	ON	ON	OFF	ON	ON
218	OFF	ON	OFF	ON	ON	OFF	ON	ON
219	ON	ON	OFF	ON	ON	OFF	ON	ON
220	OFF	OFF	ON	ON	ON	OFF	ON	ON
221	ON	OFF	ON	ON	ON	OFF	ON	ON
222	OFF	ON	ON	ON	ON	OFF	ON	ON
223	ON	ON	ON	ON	ON	OFF	ON	ON
224	OFF	OFF	OFF	OFF	OFF	ON	ON	ON
225	ON	OFF	OFF	OFF	OFF	ON	ON	ON
226	OFF	ON	OFF	OFF	OFF	ON	ON	ON
227	ON	ON	OFF	OFF	OFF	ON	ON	ON
228	OFF	OFF	ON	OFF	OFF	ON	ON	ON
229	ON	OFF	ON	OFF	OFF	ON	ON	ON
230	OFF	ON	ON	OFF	OFF	ON	ON	ON
231	ON	ON	ON	OFF	OFF	ON	ON	ON
232	OFF	OFF	OFF	ON	OFF	ON	ON	ON
233	ON	OFF	OFF	ON	OFF	ON	ON	ON
234	OFF	ON	OFF	ON	OFF	ON	ON	ON
235	ON	ON	OFF	ON	OFF	ON	ON	ON
236	OFF	OFF	ON	ON	OFF	ON	ON	ON
237	ON	OFF	ON	ON	OFF	ON	ON	ON
238	OFF	ON	ON	ON	OFF	ON	ON	ON
239	ON	ON	ON	ON	OFF	ON	ON	ON
240	OFF	OFF	OFF	OFF	ON	ON	ON	ON
241	ON	OFF	OFF	OFF	ON	ON	ON	ON
242	OFF	ON	OFF	OFF	ON	ON	ON	ON
243	ON	ON	OFF	OFF	ON	ON	ON	ON
244	OFF	OFF	ON	OFF	ON	ON	ON	ON
245	ON	OFF	ON	OFF	ON	ON	ON	ON
246	OFF	ON	ON	OFF	ON	ON	ON	ON
247	ON	ON	ON	OFF	ON	ON	ON	ON
248	OFF	OFF	OFF	ON	ON	ON	ON	ON
249	ON	OFF	OFF	ON	ON	ON	ON	ON
250	OFF	ON	OFF	ON	ON	ON	ON	ON
251	ON	ON	OFF	ON	ON	ON	ON	ON
252	OFF	OFF	ON	ON	ON	ON	ON	ON
253	ON	OFF	ON	ON	ON	ON	ON	ON
254	OFF	ON	ON	ON	ON	ON	ON	ON

SPECIFICATIONS

MECHANICAL

Construction	
Back box:	Aluminum
Dome drive:	Aluminum, ABS plastic
Lower dome:	Acrylic
Cable Entry	
In-Ceiling:	.75-inch (1.91 cm) conduit fitting
Pendant:	Through 1.5-inch (3.81 cm) NPT pendant mount
Pan Movement:	360° continuous pan rotation
Vertical Tilt:	Unobstructed +2° to -92°
Manual Pan/Tilt Speeds*	
Pan	
Spectra II:	0.1-80°/sec manual operation, 150°/sec turbo
Spectra Lite:	0.5-80°/sec manual operation, 150°/sec turbo
Tilt	
Spectra II:	0.1-40°/sec
Spectra Lite:	0.5-40°/sec
Preset Speeds	
Pan:	250°/sec
Tilt:	200°/sec

* For variable-speed operation an appropriate controller is required. With fixed-speed controllers, Spectra II and Spectra Lite pan/tilt speed is 24°/sec. The CM6700 controller with the KBD200 keyboard has programmable fixed speeds.

ELECTRICAL

Input Voltage:	18-30 VAC, 24 VAC nominal	
Input Power		
In-ceiling:	30 vA	
Indoor pendant:	30 vA	
Outdoor pendant:	75 vA	
Fuse:	1.6 A	
Relay Contacts	<u>AUX 1</u>	<u>AUX 2 Output</u>
Type:	Form C	Open collector transistor output
Voltage:	Low voltage (<40 V)	32 VDC maximum
Current:	2 A maximum	150 mA maximum

GENERAL

Environment	
In-Ceiling:	Indoor only
Pendant:	Indoor/outdoor
Operating Range	
In-Ceiling:	32 to 140°F (0 to 60°C) intermittent operation; 32 to 122°F (0 to 50°C) continuous operation
Pendant	
Without Heater:	32 to 140°F (0 to 60°C) absolute maximum operating temperature; 32 to 122°F (0 to 50°C) sustained maximum operating temperature
With Heater:	(Assumes no wind chill factor; for detailed test conditions, contact Pelco.) <u>Maximum operating temperature:</u> 140°F (60°C) absolute maximum; 122°F (50°C) sustained maximum <u>Minimum operating temperature:</u> -60°F (-51.11°C) absolute minimum; minimal icing at -50°F (-45.56°C) sustained minimum; prevents icing at -40°F (-40°C) sustained minimum; de-ices .1 inch (2.5 mm) within 3 hours after power-up
Dimensions:	See Figure 1
Ratings:	NEMA Type 1–In-ceiling back boxes, all dome drives NEMA Type 4X–Pendant back boxes IP 66–Pendant back boxes
Weight	<u>Unit</u>
Back Box	
In-ceiling:	2.17 lb (.98 kg)
Pendant Indoor:	4.45 lb (2.02 kg)
Outdoor Pendant:	4.75 lb (2.15 kg)
Dome Drive:	
Lower Dome	2.6 lb (1.18 kg)
In-ceiling:	1.6 lb (.73 kg)
In-ceiling w/cage:	
Pendant:	1.83 lb (.83 kg)
Pendant w/cage:	

(Design and product specifications subject to change without notice.)

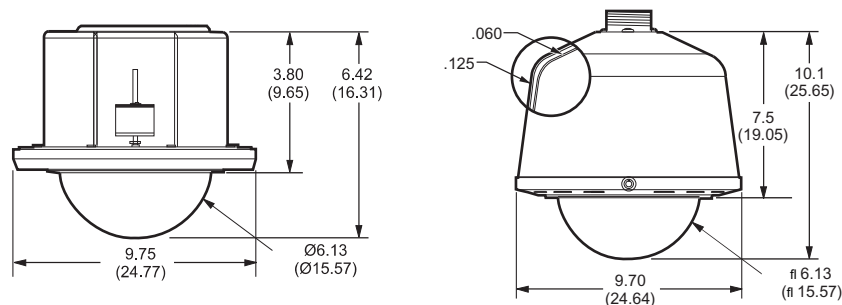

NOTE: VALUES IN PARENTHESES ARE CENTIMETERS;
 ALL OTHERS ARE INCHES

Figure 1. Dimension Drawing

PRODUCT WARRANTY AND RETURN INFORMATION

WARRANTY

Pelco will repair or replace, without charge, any merchandise proved defective in material or workmanship **for a period of one year** after the date of shipment.

Exceptions to this warranty are as noted below:

- Five years on FT/FR8000 Series fiber optic products.
- Three years on Genex® Series products (multiplexers, server, and keyboard).
- Three years on Camclosure® and fixed camera models, except the CC3701H-2, CC3701H-2X, CC3751H-2, CC3651H-2X, MC3651H-2, and MC3651H-2X camera models, which have a five-year warranty.
- Two years on standard motorized or fixed focal length lenses.
- Two years on Legacy®, CM6700/CM6800/CM9700 Series matrix, and DF5/DF8 Series fixed dome products.
- Two years on Spectra®, Esprit®, ExSite™, and PS20 scanners, including when used in continuous motion applications.
- Two years on Esprit® and WW5700 Series window wiper (excluding wiper blades).
- Eighteen months on DX Series digital video recorders, NVR300 Series network video recorders, and Endura™ Series distributed network-based video products.
- One year (except video heads) on video cassette recorders (VCRs). Video heads will be covered for a period of six months.
- Six months on all pan and tilts, scanners or preset lenses used in continuous motion applications (that is, preset scan, tour and auto scan modes).

Pelco will warrant all replacement parts and repairs for 90 days from the date of Pelco shipment. All goods requiring warranty repair shall be sent freight prepaid to Pelco, Clovis, California. Repairs made necessary by reason of misuse, alteration, normal wear, or accident are not covered under this warranty.

Pelco assumes no risk and shall be subject to no liability for damages or loss resulting from the specific use or application made of the Products. Pelco's liability for any claim, whether based on breach of contract, negligence, infringement of any rights of any party or product liability, relating to the Products shall not exceed the price paid by the Dealer to Pelco for such Products. In no event will Pelco be liable for any special, incidental or consequential damages (including loss of use, loss of profit and claims of third parties) however caused, whether by the negligence of Pelco or otherwise.

The above warranty provides the Dealer with specific legal rights. The Dealer may also have additional rights, which are subject to variation from state to state.

If a warranty repair is required, the Dealer must contact Pelco at (800) 289-9100 or (559) 292-1981 to obtain a Repair Authorization number (RA), and provide the following information:

1. Model and serial number
2. Date of shipment, P.O. number, Sales Order number, or Pelco invoice number
3. Details of the defect or problem

If there is a dispute regarding the warranty of a product which does not fall under the warranty conditions stated above, please include a written explanation with the product when returned.

Method of return shipment shall be the same or equal to the method by which the item was received by Pelco.

RETURNS

In order to expedite parts returned to the factory for repair or credit, please call the factory at (800) 289-9100 or (559) 292-1981 to obtain an authorization number (CA number if returned for credit, and RA number if returned for repair).

All merchandise returned for credit may be subject to a 20% restocking and refurbishing charge.

Goods returned for repair or credit should be clearly identified with the assigned CA or RA number and freight should be prepaid. Ship to the appropriate address below.

If you are located within the continental U.S., Alaska, Hawaii or Puerto Rico, send goods to:

Service Department
Pelco
3500 Pelco Way
Clovis, CA 93612-5699

If you are located outside the continental U.S., Alaska, Hawaii or Puerto Rico and are instructed to return goods to the USA, you may do one of the following:

If the goods are to be sent by a COURIER SERVICE, send the goods to:

Pelco
3500 Pelco Way
Clovis, CA 93612-5699 USA

If the goods are to be sent by a FREIGHT FORWARDER, send the goods to:

Pelco c/o Expeditors
473 Eccles Avenue
South San Francisco, CA 94080 USA
Phone: 650-737-1700
Fax: 650-737-0933

Pelco, the Pelco logo, Camclosure, Esprit, Genex, Legacy, and Spectra are registered trademarks of Pelco.
Endura and ExSite are trademarks of Pelco.
Loctite is a registered trademark of Loctite Corporation.
©Copyright 2000, Pelco. All rights reserved.
U.S. Patent No. 5,931,432.

REVISION HISTORY

Manual #	Date	Comments
C2429M	3/01	Original version.